

PART NAME NEMA 4X ENCLOSURE

PART No.

PN-1332, PN-1332-C AND PN-1332-DG

INDUSTRY STANDARDS:
 POLYCARBONATE (LIGHT GRAY AND CLEAR)
 UL94V-2 FLAMMABILITY RATING (UL FILE #E41613)
 UV STABILIZED
 SERVICE TEMPERATURE RANGE: -40°C TD +120°C
 ABS (DARK GRAY)
 UL94-HB FLAMMABILITY RATING (UL FILE #E56070)
 SERVICE TEMPERATURE RANGE: -40°C TD +80°C

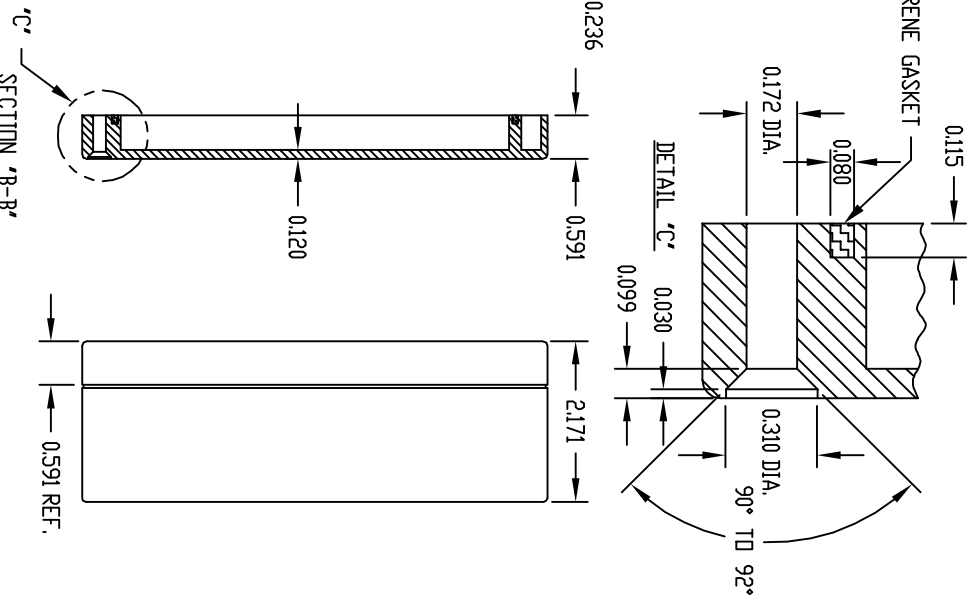
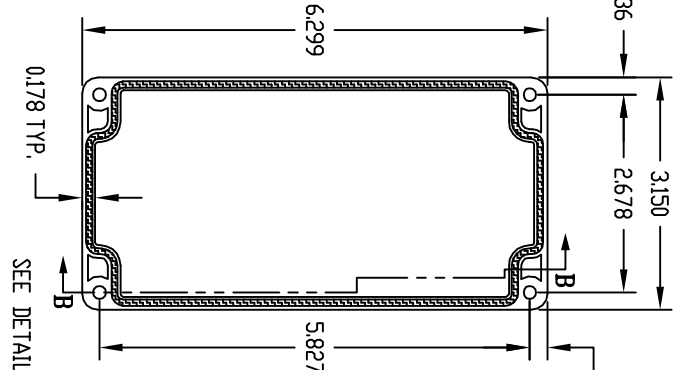
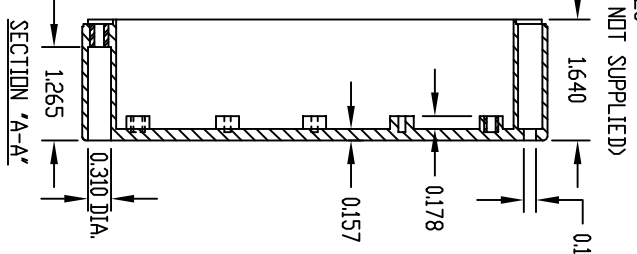
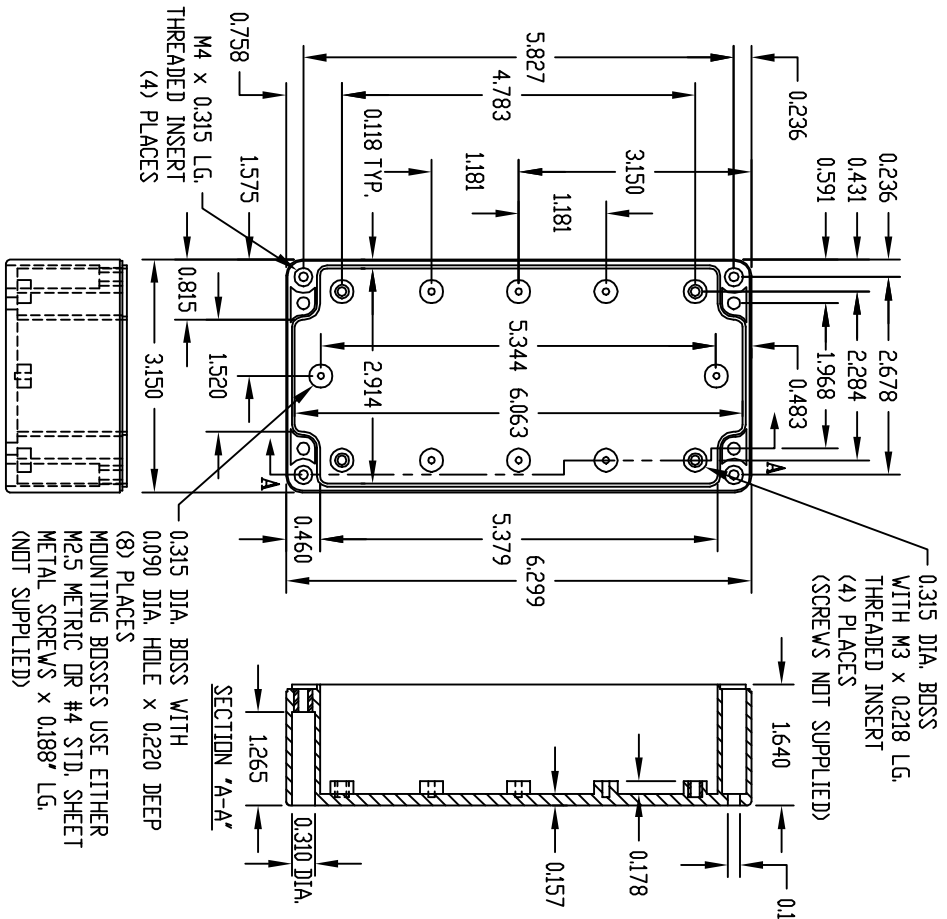

NOTE: ALL DIMENSIONS HAVE ±0.015 TOLERANCE UNLESS OTHERWISE SPECIFIED.

PART NUMBER	MATERIAL	FINISH	HARDWARE KIT
PN-1332	POLYCARBONATE	LIGHT GRAY	KIT CONTAINS (4) M4 x 20mm (0.787") LG. SCREWS FOR ASSEMBLY
PN-1332-C	POLYCARBONATE	CLEAR	
PN-1332-DG	HIGH-IMPACT ABS	DARK GRAY	